

The above lights are designed for use on power driven vessels under 12 meters (39.4 ft.) in length operating at a nominal 12 volt system. In order to comply with '72 COLREGS and the U.S. Inland Rules, the following must be adhered to:

MOUNTING INFORMATION

Read all instructions before proceeding.

- 1). For proper light selection, positioning and configuration, refer to A.B.Y.C. Standard A-16*, the '72 COLREGS*', and the U.S. Inland Rules*.
- 2). These lights are designed to be mounted on a horizontal surface.
- 3). Draw a 6 inch long reference line through the center of the selected mounting location and parallel to the centerline of the boat.
- 4). Cut out the proper mounting template. Place it on the mounting surface such that the reference line (drawn in step 3) is directly underneath the reference line marked on the template.
- 5). Drill indicated holes through the appropriate template to accommodate #8 oval head mounting screws and socket.
- 6). Attach supply connections to the light, making sure to wire in accordance with both A.B.Y.C. Standard E-11* and U.S. Coast Guard Safety Standards for Boat Electrical Systems (33 CFR 183)*.

The supply leads are coded as follows:

WHITE: Forward compartment (Bi-color) positive supply lead.
GRAY: Aft compartment (Utility) positive supply lead.
BLACK: Negative supply lead. (Caution: Negative lead connected to case. To avoid energizing case, observe polarity).

Electrical connections must be made such that the forward compartment is switched in conjunction with the other running light(s); aft compartment (utility light) should be switched with Ignition (or permanently energized), as a push switch is provided on top of the light.

NOTE: All light circuits must be circuit protected. Use a 1/2 AMP fuse (or breaker) for the courtesy light circuit and a 2 AMP fuse (or breaker) for the combination light circuit.

- 7). Mount the base in accordance with the template.
- 8). **IMPORTANT:** Top of light must be vertical during operation (See Diagram #1).
- 9). Setup for Operation:

Insert pole in base, making sure alignment screw in pole slides into the notch in the base. Push pole down until it engages the electrical connector and lock by rotating the locking collar clockwise. **Remove and store the pole light and replace weatherproof cover on base when not in use.**

- 10). Lamp replacement: Use Perko Cat. No. 0071DP0CLR, 12V, 10W for forward compartment (Bi-Color) and Perko Cat. No. 0064000CLR for aft compartment (Utility Light).

• The above referenced standards can be obtained from:

- (1). American Boat & Yacht Council, Inc.
613 Third Street, Suite 10
Annapolis, MD 21403
- (2). U.S. Coast Guard
Washington, D.C. 20593
(or your local C.G. office)

DIAGRAM #1



Note: Top of Light must be vertical during Operation.

PERKO, Inc.
16490 N.W. 13th. Avenue
Miami, FL. 33169-5707
www.perko.com

Fig. 1211
MOUNTING TEMPLATE

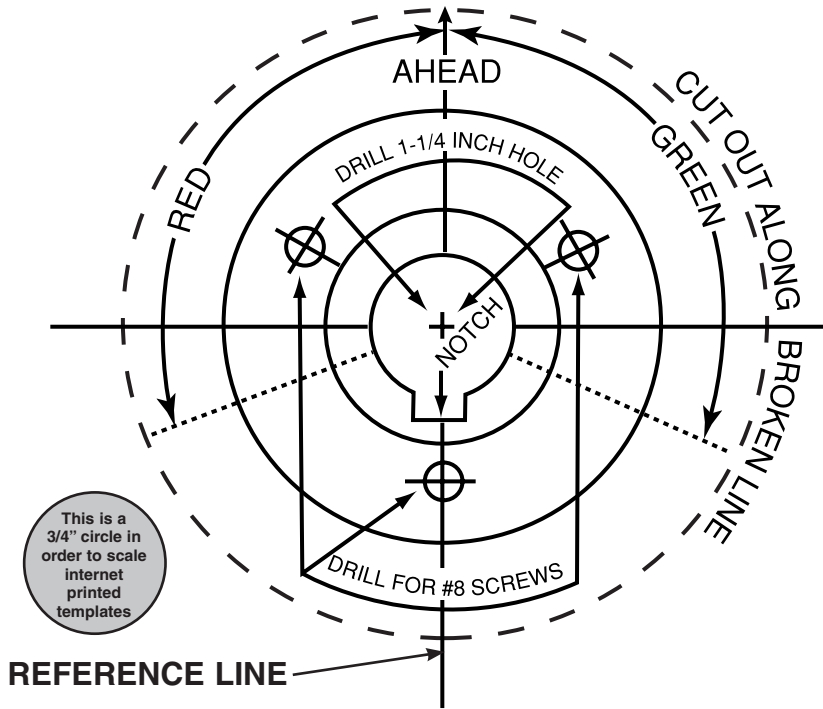
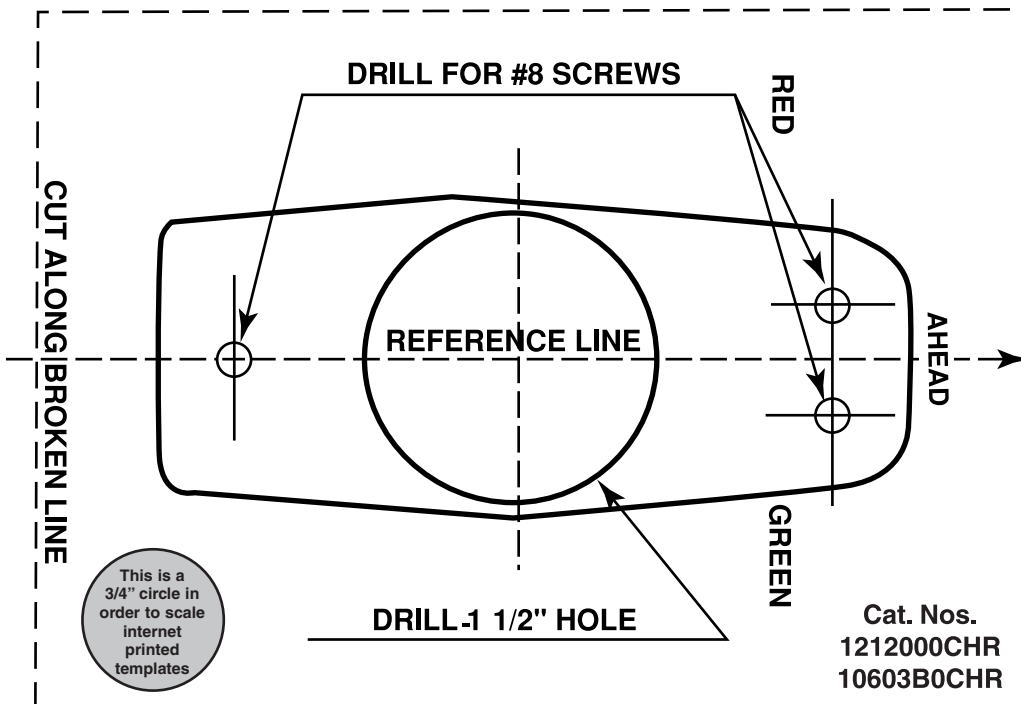

Fig. 1212
MOUNTING TEMPLATE



Cat. Nos.
1212000CHR
10603B0CHR